

DISINFECTION GATE 360°

- **WATER CONSUMPTION:** from 30 l/min up to 110l/min
- Chemical solution consumption (water + chemicals) 11l-35l/track
- **DISINFECTION TIME:** 15-25 sek/ truck
- **DISINFECTION FRAME:** powder coated aluminum
- Stainless or PVC spraying system
- 9 - 13 nozzles undercarriage spraying system
- Equipped with a 230V or 400V powered pump
- Automatic chemical dilution
- 33 - 48 pcs spray nozzles, different types
- 25m hose for spraying in inaccessible spots
- **REMOTE CONTROL:** start/stop function
- **VEHICLE DETECTORS AND REMOTE CONTROLLERS:** Automatic start/stop function - Vehicle detectors and remote controllers
- Manual start push button
- **HEATING:** a heating system with built-in thermostat that starts heating when the temperature drops below 0°C
- **STORAGE:** Component Storage keeps inside pumps, chemical containers, control panel, dilution systems, etc.
- **LARGE STORAGE:** Component Storage keeps inside 600l clean water tank, pumps, chemical containers, control panel, dilution systems, etc.
- Night visibility elements
- **COLOR:** yellow or made to order
- **DIMENSION:** 470cm x 400cm, 470cm x 450cm (can be made with any size)



DISINFECTION GATE for Biosecurity

Disinfection Gate for 360 ° vehicle disinfection, design for spraying any type of passing thru vehicles like agricultural machinery, poultry trucks, passenger cars. Prevents the transfer of diseases to the farm, danger zone.

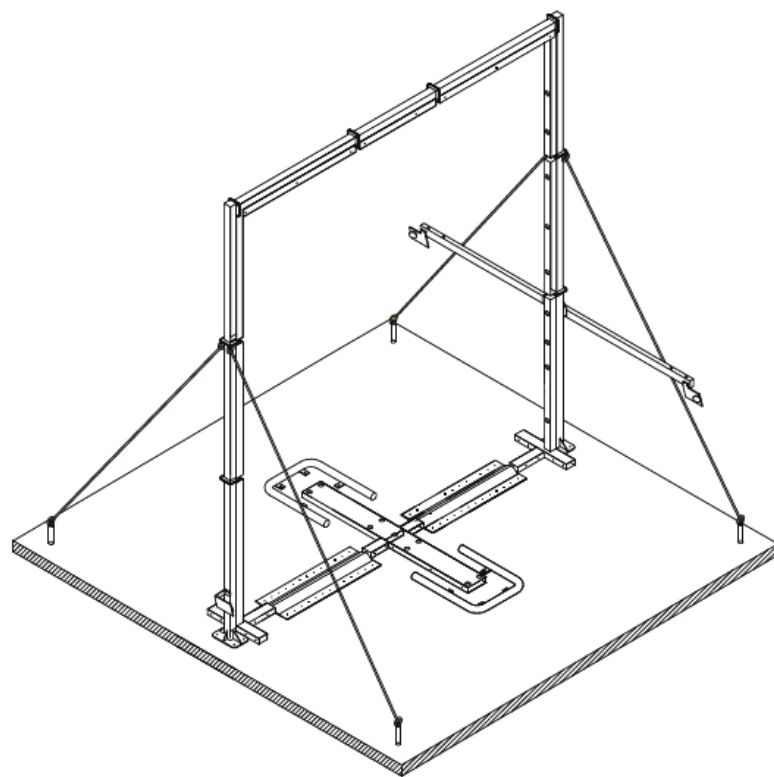

CHEMICAL DILUTION RATE

Tip No.	1	2	3	4	5	6	7	8	9	10	11	No Tip	
% solution	0,3	0,5	0,8	1	1,3	1,5	1,5	2	2,5	3	5	7	14